

User Guide

# AmberLink™

Wireless emergency response system



**Visonic®**

*For a secure way of life*

## WARRANTY

Visonic Limited (the "Manufacturer") warrants this product only (the "Product") to the original purchaser only (the "Purchaser") against defective workmanship and materials under normal use of the Product for a period of twelve (12) months from the date of shipment by the Manufacturer.

This Warranty is absolutely conditional upon the Product having been properly installed, maintained and operated under conditions of normal use in accordance with the Manufacturers recommended installation and operation instructions. Products which have become defective for any other reason, according to the Manufacturers discretion, such as improper installation, failure to follow recommended installation and operational instructions, neglect, willful damage, misuse or vandalism, accidental damage, alteration or tampering, or repair by anyone other than the manufacturer, are not covered by this Warranty.

The Manufacturer does not represent that this Product may not be compromised and/or circumvented or that the Product will prevent any death and/or personal injury and/or damage to property resulting from burglary, robbery, fire or otherwise, or that the Product will in all cases provide adequate warning or protection. The Product, properly installed and maintained, only reduces the risk of such events without warning and it is not a guarantee or insurance that such events will not occur.

**THIS WARRANTY IS EXCLUSIVE AND EXPRESSLY IN LIEU OF ALL OTHER WARRANTIES, OBLIGATIONS OR LIABILITIES, WHETHER WRITTEN, ORAL, EXPRESS OR IMPLIED, INCLUDING ANY WARRANTY OF MERCHANTABILITY OR FITNESS FOR A PARTICULAR PURPOSE, OR OTHERWISE. IN NO CASE SHALL THE MANUFACTURER BE LIABLE TO ANYONE FOR ANY CONSEQUENTIAL OR INCIDENTAL DAMAGES FOR BREACH OF THIS WARRANTY OR ANY OTHER WARRANTIES WHATSOEVER, AS AFORESAID.**

**THE MANUFACTURER SHALL IN NO EVENT BE LIABLE FOR ANY SPECIAL, INDIRECT, INCIDENTAL, CONSEQUENTIAL OR PUNITIVE DAMAGES OR FOR LOSS, DAMAGE, OR EXPENSE, INCLUDING LOSS OF USE, PROFITS, REVENUE, OR GOODWILL, DIRECTLY OR INDIRECTLY ARISING FROM PURCHASER'S USE OR INABILITY TO USE THE PRODUCT, OR FOR LOSS OR DESTRUCTION OF OTHER PROPERTY OR FROM ANY OTHER CAUSE, EVEN IF MANUFACTURER HAS BEEN ADVISED OF THE POSSIBILITY OF SUCH DAMAGE.**

**THE MANUFACTURER SHALL HAVE NO LIABILITY FOR ANY DEATH, PERSONAL AND/OR BODILY INJURY AND/OR DAMAGE TO PROPERTY OR OTHER LOSS WHETHER DIRECT, INDIRECT, INCIDENTAL, CONSEQUENTIAL OR OTHERWISE, BASED ON A CLAIM THAT THE PRODUCT FAILED TO FUNCTION.**

However, if the Manufacturer is held liable, whether directly or indirectly, for any loss or damage arising under this limited warranty, **THE MANUFACTURER'S MAXIMUM LIABILITY (IF ANY) SHALL NOT IN ANY CASE EXCEED THE PURCHASE PRICE OF THE PRODUCT**, which shall be fixed as liquidated damages and not as a penalty, and shall be the complete and exclusive remedy against the Manufacturer.

When accepting the delivery of the Product, the Purchaser agrees to the said conditions of sale and warranty and he recognizes having been informed of. Some jurisdictions do not allow the exclusion or limitation of incidental or consequential damages, so these limitations may not apply under certain circumstances.

The Manufacturer shall be under no liability whatsoever arising out of the corruption and/or malfunctioning of any telecommunication or electronic equipment or any programs.

The Manufacturers obligations under this Warranty are limited solely to repair and/or replace at the Manufacturer's discretion any Product or part thereof that may prove defective. Any repair and/or replacement shall not extend the original Warranty period. The Manufacturer shall not be responsible for dismantling and/or reinstallation costs. To exercise this Warranty the Product must be returned to the Manufacturer freight pre-paid and insured. All freight and insurance costs are the responsibility of the Purchaser and are not included in this Warranty.

This warranty shall not be modified, varied or extended, and the Manufacturer does not authorize any person to act on its behalf in the modification, variation or extension of this warranty. This warranty shall apply to the Product only. All products, accessories or attachments of others used in conjunction with the Product, including batteries, shall be covered solely by their own warranty, if any. The Manufacturer shall not be liable for any damage or loss whatsoever, whether directly, indirectly, incidentally, consequentially or otherwise, caused by the malfunction of the Product due to products, accessories, or attachments of others, including batteries, used in conjunction with the Products. This Warranty is exclusive to the original Purchaser and is not assignable.

This Warranty is in addition to and does not affect your legal rights. Any provision in this warranty which is contrary to the Law in the state or country where the Product is supplied shall not apply.

**Warning:** The user must follow the Manufacturer's installation and operational instructions including testing the Product and its whole system at least once a week and to take all necessary precautions for his/her safety and the protection of his/her property.

1/08

# Table of Contents

<b>WIRELESS EMERGENCY RESPONSE SYSTEM</b> .....	<b>4</b>
<b>SPECIFICATIONS</b> .....	<b>6</b>
General Data .....	6
Physical Properties .....	7
<b>SYSTEM SETUP</b> .....	<b>7</b>
Select Unit Location .....	7
Connect the Unit to your Telephone Line .....	7
Installing a GSM Module (optional).....	9
Program the Panel .....	11
Connect Power to AmberLink (see Fig. 3b).....	12
Connecting the AmberLink to the Monitoring Center .....	12
Enrolling Transmitters .....	13
Deleting Wireless Transmitters from the System Memory.....	14
Wireless Devices Test.....	14
Reset to Factory Default .....	14
<b>MOUNTING THE UNIT</b> .....	<b>15</b>
Mounting the Unit on a Table (Fig. 4) .....	15
Mounting the Unit on the Wall .....	15
<b>Using your AmberLink</b> .....	<b>16</b>
Using your Pendant Transmitter .....	16
Calling for Emergency Assistance .....	16
Trouble .....	17
Remote control by telephone .....	17
<b>MAINTAINING YOUR SYSTEM</b> .....	<b>18</b>
Pendant transmitter Test.....	18
When a Pendant's Battery is Low .....	18
When a Smoke Detector's Battery is Low.....	18
Unit Battery Replacement .....	19
<b>APPENDIX A: HOME FIRE ESCAPE PLANNING</b> .....	<b>20</b>
<b>APPENDIX B: SIA EVENT CODES</b> .....	<b>21</b>
<b>APPENDIX C: CONTACT ID EVENT CODES</b> .....	<b>21</b>
<b>APPENDIX D: COMPLIANCE and STATEMENTS</b> .....	<b>23</b>
Compliance .....	23
Statement .....	23
Statement .....	23
<b>APPENDIX E: CUSTOMER PREMISES EQUIPMENT AND WIRING</b> .....	<b>24</b>
Customer Information.....	25

# WIRELESS EMERGENCY RESPONSE SYSTEM

Congratulations on your purchase of the wireless AmberLink™ Personal Emergency Response system.

This home health care signaling system was designed to support people in their home environment. In the event of an emergency, help can be summoned at the press of a button and that same message can be sent to private numbers that you have selected for notification. In the event of fire, the system can be programmed to automatically call the monitoring station or to private phones.

Local and Remote Programming may be performed over telephone and GSM connections.

The Unit's LEDs show the system status.

The Unit's rechargeable backup battery provides backup operation. When AC power is restored, the backup battery is automatically recharged.

## What's Included

Before you begin to set up your system, make sure you have all the necessary components.

- AmberLink Unit
- Transformer Input 120VAC 60 Hz / Output 9VAC 0.1A
- Pendant transmitters supplied with necklace

## Additional Accessories (Optional)

- USB Programming Cable or RS-232 Dual Programming Cable and Adaptor
- Supervised wireless smoke detector (MCT-426)
- Waterproof arm/disarm security activation pendant transmitter (MCT-201 WP)
- Fully supervised indoor, PowerCode, flood detector (MCT-550)
- Wristband supplied for (MCT-212)
- Pet-Immune PowerCode wireless PIR motion detector (NEXT K9-85)
- Supervised PowerCode magnetic contact transmitter (MCT-302)
- Microprocessor controlled wireless repeater (MCX-600PERS)
- Supervised wireless emergency button (MCT-220)

The system unit is shown in Figure 1.

**Note:** All of the listed transmitters have a PERS suffix. In addition, the "txid" code of each transmitter is printed on the packaging.

**Note:** PowerCode refers to Visonic's proprietary communications protocol which makes use of unique ID codes.



AmberLink

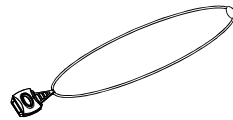

MCT-212



MCT-211

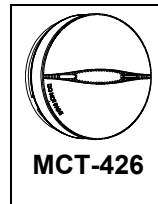

MCT-426

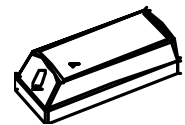

MCT-550  
(Flood Detector)



MCT-442

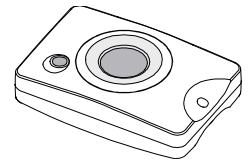

MCT-201 WP

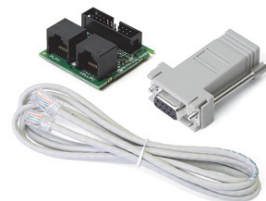

RS-232 Dual Programming  
Cable



NEXT K9-85

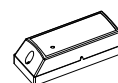

MCT-302

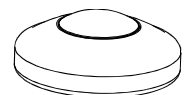

MCT-220

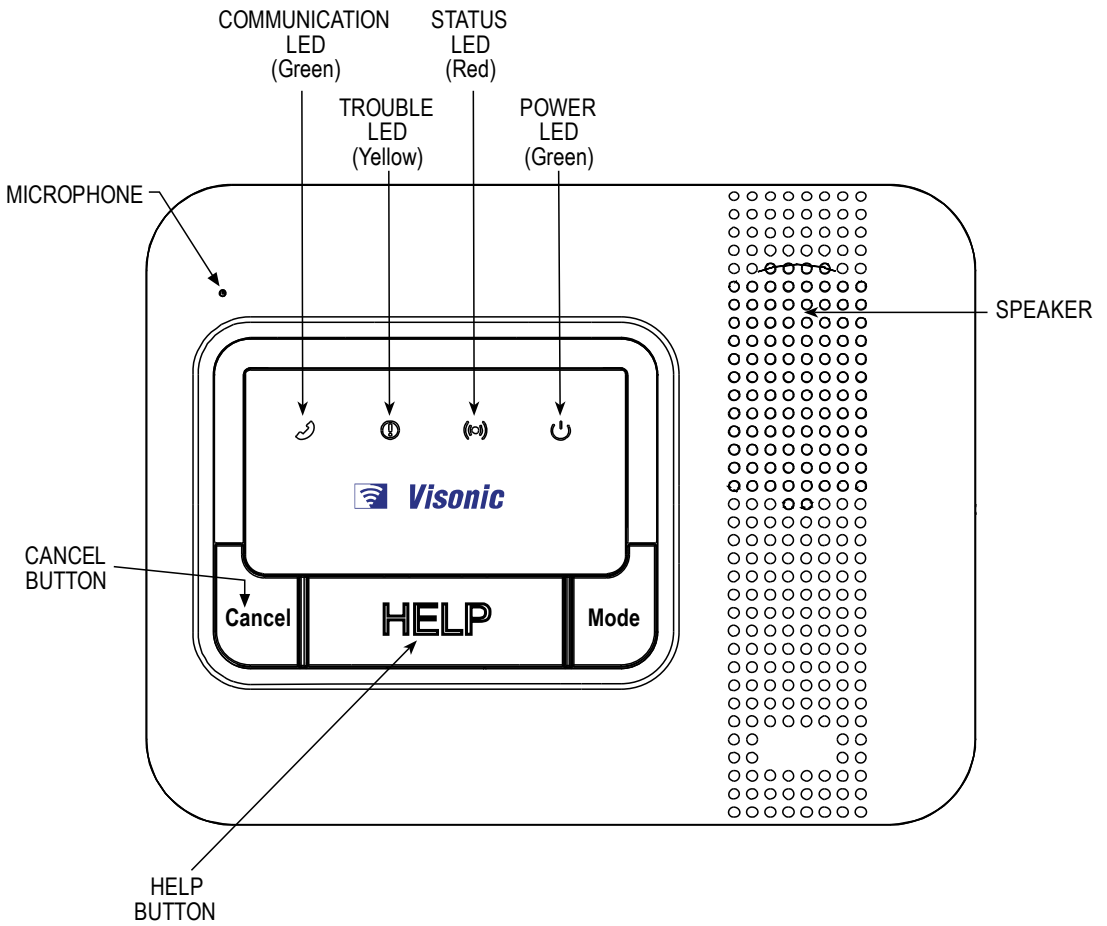

**Figure 1 – Front View**

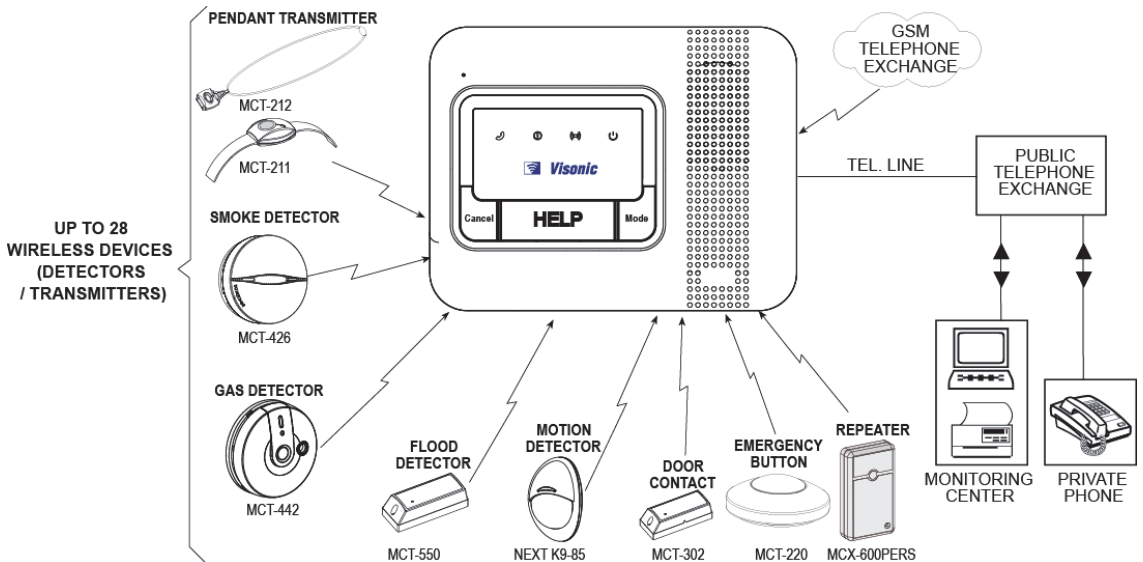

**Figure 2 – System Configuration**

# SPECIFICATIONS

## General Data

**Pendant Transmitter Battery Life:** 6 years (for typical use)

**Frequency (MHz):** 315, 868.

**Indicators:** 4 LED indicators.

**Battery Pack:** NI-MH 7.2 V, 1.3 Ah

**Electric Power:** 9VAC/0.1A (via 120VAC/60Hz transformer).

**Compliance:** Complies with FCC part 68 and part 15, and UL 1637 Home Health Care Signaling Equipment. MCT-426 is designed to comply with UL 268 and UL 985.

**Note:** *The 315 MHz version only was tested for compliance with UL standards UL 1637; UL 1635; UL 985; ULC S545-02; CSA C22.2.*

The system shall be installed in accordance with Chapter 2 of the National Fire Alarm Code, ANSI/NFPA 72 (National Fire Protection Association, Batterymarch Park, Quincy, MA 02269).

### LEDs:

	Indicator	Behavior	Significance
1	RF Indication LED	Lights steadily for 3 sec.	Received RF signal with strong or good RSSI from any enrolled transmitter.
		Blinks	Received RF signal with poor RSSI from any enrolled transmitter.
		No light	No RF signal received.
2	Trouble LED	Lights steadily	Indicates system trouble.
		Blinks	When GSM RSSI is poor.
		No light	No trouble.
3	Communication LED	Light steadily	Communication via PSTN/GSM is online.
		Blinks	Phone line failure or is disconnected (Trouble LED also lights steadily in this condition).
		No light	Communication via PSTN/GSM is offline.
4	Power LED	Lights steadily	AC power is connected.
		Blinks	AC power is connected but battery is low.
		No light	AC power is not connected.
5	Backlight LEDs	Lights steadily	When the conditions below do not exist.
		Blinks	When there is AC failure.
		No light	When red indication LED blinks. The left backlight LED between the "HELP" and "CANCEL" buttons turns OFF.

## Special Functions:

- Calling for help by using an emergency pendant transmitter
- Speakerphone (hands-free) when communicating with Monitoring Center or when answering an incoming call by pressing the pendant
- The system supports up to 28 users (pendant transmitters and smoke detectors).
- Computer control and data download/upload
- Remote control by telephone
- Remote diagnostic and event log using PC software

## Physical Properties

**Operating Temperature:** 32°F to 104°F (0°C to 40°C)

**Storage Temperature:** -4°F to 140°F (-20°C to 60°C)

**Size:** 9-13/16 x 7-1/4 x 2-5/16 in. (248 x 185 x 55 mm).

**Weight:** 3 lb (1.35 kg)

**Color:** Off-white

**Note:** *The product supports all standard monitoring center receivers.*

## SYSTEM SETUP

To set up your system, follow the steps below.

### Select Unit Location

If possible, select a central location in your home for the Unit. This location should be in the area where you spend most of your time. The location should also enable an optimal signal reception for pendants and smoke detectors.

The Unit can be placed on a table, desk, or counter. It also can be mounted on a wall.

Make sure that the location you have selected is near an electrical outlet and a phone jack.

### Connect the Unit to your Telephone Line

The AmberLink communicates with your Monitoring Center through your telephone line.

1. Locate the phone jack on your wall where you want to connect your AmberLink. If a phone is already plugged into that jack, unplug it and connect it to the "PHONE" connector on the back of the AmberLink. Your telephone will still function normally.
2. Connect the wide end (RJ-45) of the phone cord to the "Wall Jack" on your AmberLink. Plug the narrow end (RJ-11) of that phone cord into the phone jack on your wall. The AmberLink is now connected to your telephone line.

**Note:** *Be aware of other phone line services such as DSL. If DSL service is present on the phone line, you must install a filter. See Figures 3a and 3b for proper installation.*

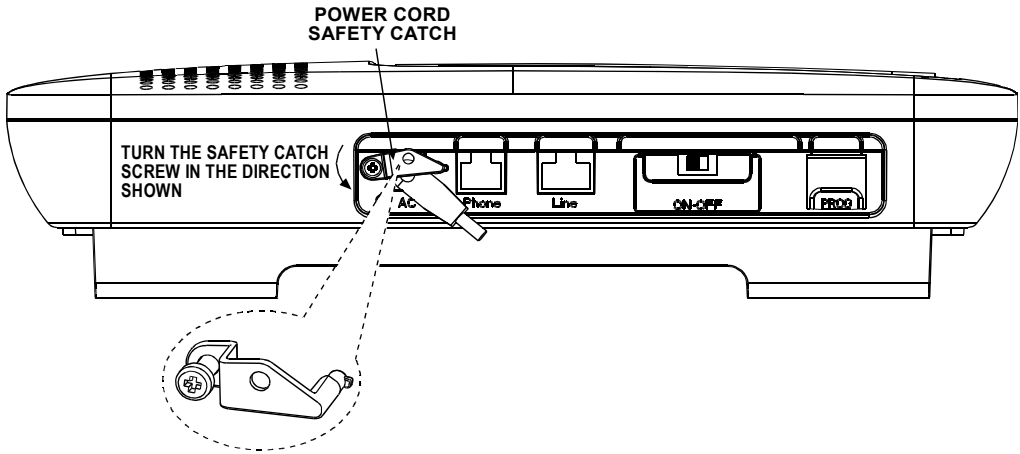

**Figure 3a**

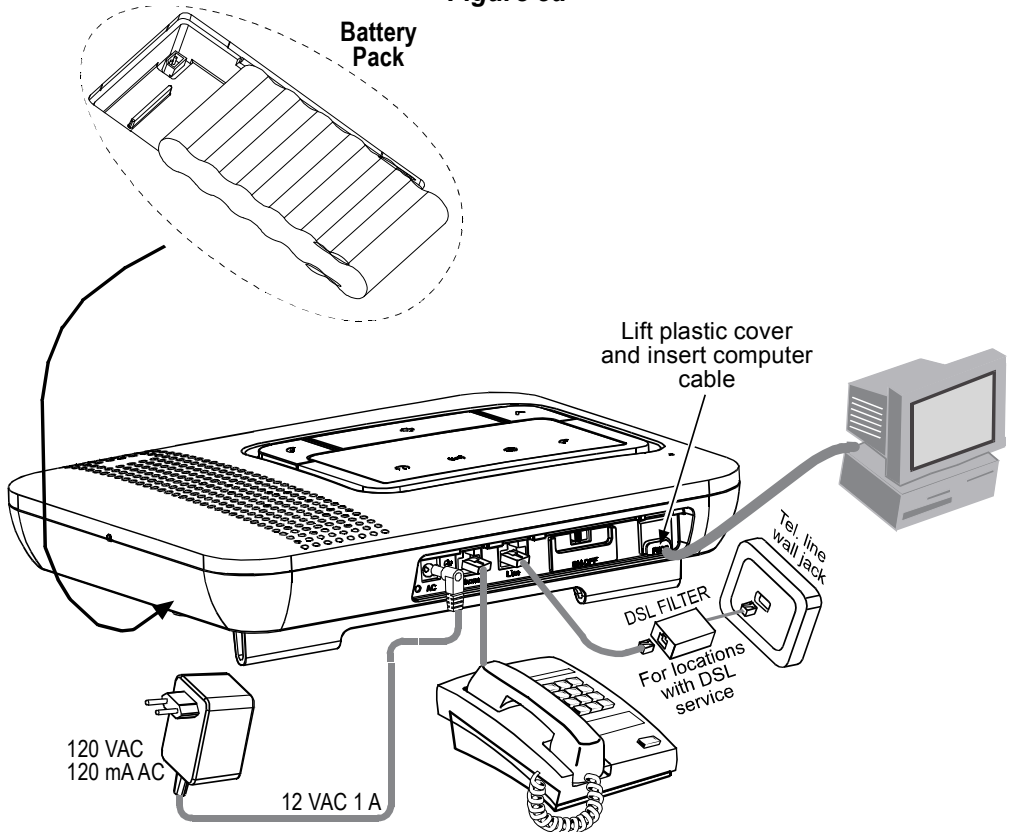

**Figure 3b – Installation: Power, Telephone and Tel. line battery Connection**

**Note:** It is recommended that the AC power input, the Remote Programmer computer connection, and the telephone be interconnected within the same room.

## Installing a GSM Module (optional)

As an option, an internal GSM 350 module enables the AmberLink system to operate over a GSM cellular network. AmberLink connects over GSM to the Central Monitoring Station (CMS), therefore allowing you to send reports to the CMS and SMS messages to other private phone users.

The GSM modem auto detection feature enables automatic enrollment of the GSM modem into the AmberLink panel memory. GSM modem auto detection is activated after reset (device power-up).

**CAUTION:** Make sure that the AmberLink panel is powered OFF and disconnected from the mains power before opening the panel.

### Inserting the GSM Module into the AmberLink Panel

1. Open the battery enclosure on the back cover, disconnect the battery and remove it.

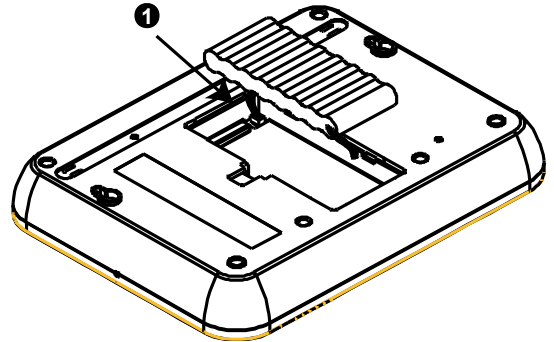

Figure 4a – Removing the battery

2. Loosen and remove the four screws which secure the panel.
3. Remove the back panel cover and place it aside temporarily.

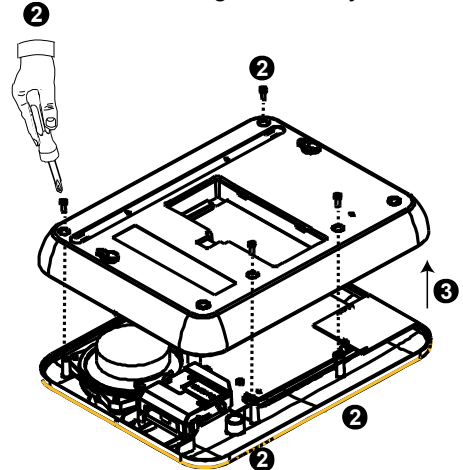
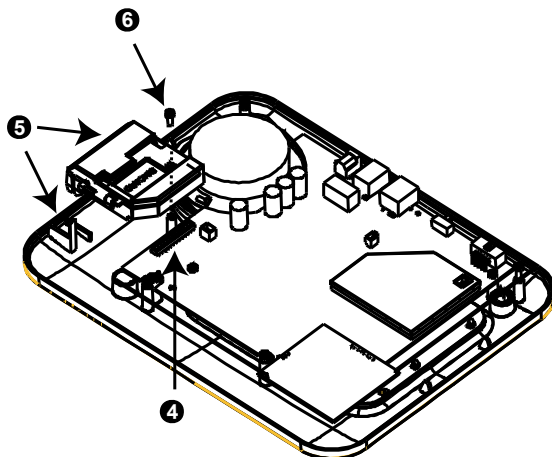

Figure 4b – Removing the back panel cover

4. Insert the GSM module to its designated location on the front cover. First, plug the module pins into the pin connector.
5. Lower the GSM module so that the grooves on both sides fit onto the rails situated on the cover.
6. Secure the GSM module in place by tightening its screw.
7. Close the panel covers, tightening the four screws (removed in step 2) to secure the panel shut.
8. Reconnect the panel's battery and return it to the battery enclosure, and close the enclosure's cover.

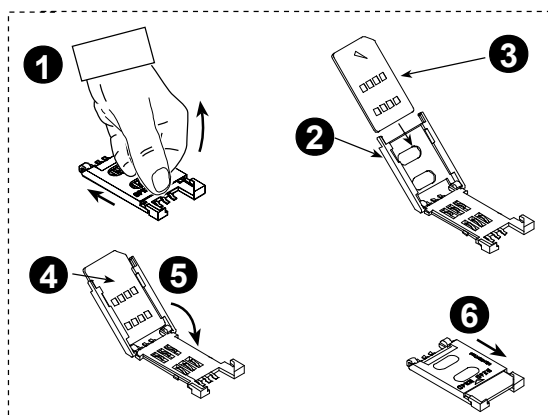

**Figure 4c – Inserting the GSM module**

### **Inserting the GSM Module's SIM Card**

To enable GSM communication with the CMS, a standard universal SIM card with Voice and Text in "Activated" state is required. Make sure the SIM card has sufficient voice minutes and SMS allowance before installation. Insert the SIM card into the GSM module as described below.

1. Slide the top cover.
2. Open the cover.
3. Align the SIM card to the cover (note the SIM card's orientation as you insert it).
4. Slide the SIM card into the cover.
5. Rotate the cover to close.
6. Lock the cover.



**Figure 5 – Inserting the SIM card**

## Attaching an External Antenna to the GSM Module

(Optional)

1. Break off the plastic flap (located in the antenna opening) from the AmberLink panel's back cover.
2. Place the optional GSM external antenna on the site surface, connect its connector to the internal GSM module and thread the antenna wire through the opening on the AmberLink front panel.
3. Close the panel covers, tightening the four screws to secure the panel shut.

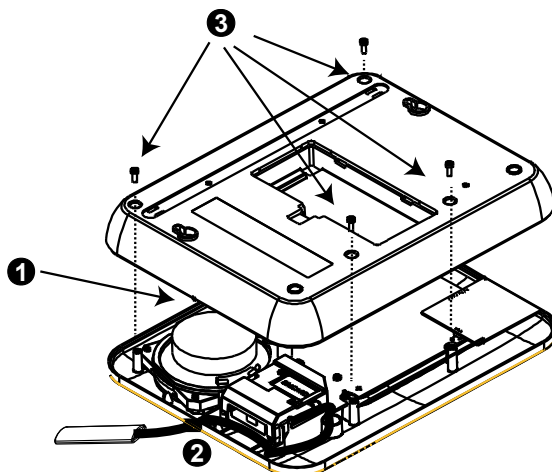

Figure 6a – Connecting an external antenna

**CAUTION:** When removing the optional external antenna, hold its connector (not the cable) and pull it out. This prevents damage to the PCB.

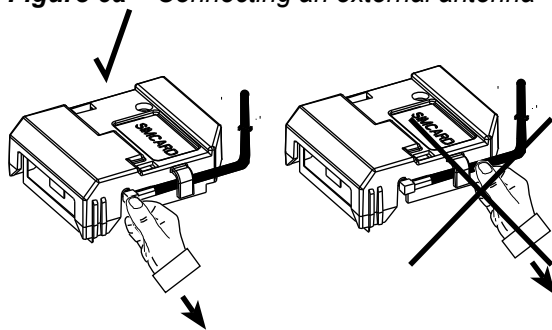

Figure 6b – Removing the external antenna

## Program the Panel

### Local setup

**Note:** To download and install the PC Remote Programmer, you need to receive the following from your authorized Visonic dealer:

- FTP Server location and temporary login details
- Operator code and password required to install the AmberLink program.

1. Log in to the FTP site and enter the **AmberLink Software** folder.
2. Download the contents of this folder to your PC.
3. To run the downloaded installation file and continue AmberLink installation, enter the AmberLink operator code and password when prompted.
4. Complete the installation as instructed on your PC screen.
5. Lift the plastic Prog cover on the AmberLink panel and attach the USB programming cable or the RS-232 Dual Programming Cable to the appropriate connector. Connect the other end to your PC USB port or RS-232 serial port.
6. Enter all the desired programming information into the PC Remote Programmer (see the *Remote Programmer User Guide* for details).

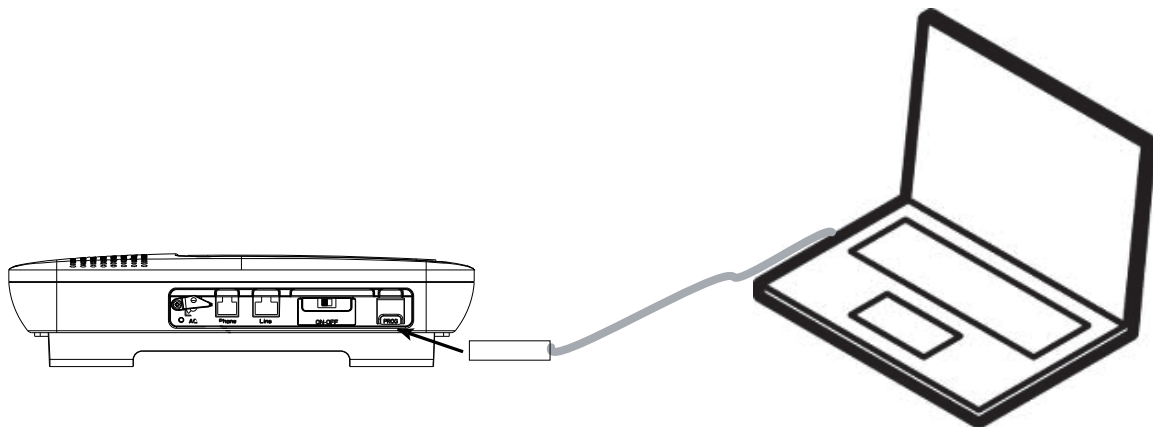

**Figure 7 – Connecting the RS-232/USB programming cable**

## **Remote setup**

1. Enter all the desired programming information into the PC Remote Programmer.
2. Connect to the remote panel via a dial-up modem attached to the PC.

## **Connect Power to AmberLink** (see Fig. 3b)

During normal operation, your AmberLink runs on electrical power.

1. Insert the plug on the power cord into the "AC" connector on the AmberLink.
2. Insert the safety catch tab horizontally into the hole to the right of the power cord plug, as shown in Figure 3a.
3. Turn the safety catch screw, observing the polarity of the arrow in Figure 3a, until facing the other hole. Then secure the screw.
4. Connect the AC/AC adapter into a nearby electrical outlet. **DO NOT USE AN OUTLET CONTROLLED BY A WALL SWITCH.**
5. Turn the ON/OFF switch to ON. The unit sends the Power On notification to the Central Station and a "Happy Tune" plays (when you turn the switch off, the unit sends a Power Off notification and you hear a "Sad Tune").

**Caution:** When the plug is removed the unit is disconnected from the mains supply and will run on the battery pack.

When electrical power is supplied the green light on the front panel illuminates.

## **Connecting the AmberLink to the Monitoring Center**

After you complete the steps above your AmberLink will automatically call your Central Station provided that your unit was programmed to report to Central Station (and not to private telephones). Once this feature has been tested, the operator must disconnect by pressing DTMF '99'.

**Note:** Certain remote areas of your residence may lie outside the reception range of the AmberLink, resulting in the unit not being able to receive transmissions directly. In this case, a Repeater (MCX-600PERS) can be used to increase the AmberLink reception range.

For further details, please contact the company from where the products were purchased.

# Enrolling Transmitters

By using a remote / local PC programmer, it is possible to enroll up to 28 transmitters in the AmberLink and to program the panel as well.

## Without PC:

Up to 15 wireless devices / transmitters can be enrolled locally without a PC. The AmberLink will recognize the device type according to it's ID:





1. Press and hold for 6 seconds both the "CANCEL" button and the MODE button. All 4 LEDs should flash to indicate that the system is in programming mode.
2. To select the desired transmitter location (zone) number, click the MODE button (displays the next menu) or the "HELP" button (displays the previous menu) repeatedly until the desired transmitter location number is displayed (see Table below). Each press advances to the next location (zone) number (1 - 15).

The LEDs lights combination indicates the Location / zone number, as shown in Table 1:

**Flashing light** = Free location into which a transmitter can be enrolled.

**Steady light** = Occupied location with an enrolled transmitter.

**Table 1 - Zone Number Indication**

ZONE No.	LED			
				
1	ON	-	-	-
2	-	ON	-	-
3	ON	ON	-	-
4	-	-	ON	-
5	ON	-	ON	-
6	-	ON	ON	-
7	ON	ON	ON	-
8	-	-	-	ON
9	ON	-	-	ON
10	-	ON	-	ON
11	ON	ON	-	ON
12	-	-	ON	ON
13	ON	-	ON	ON
14	-	ON	ON	ON
15	ON	ON	ON	ON
16 (Global Zones clear)	-	-	-	-

3. When the LEDs of the desired location flash, activate the desired transmitter. A success beep should be heard and the proper LEDs combination (see Table 1) should stop flashing and light constantly.
4. To verify that the specific transmitter was properly enrolled, reactivate the transmitter once again and verify that all 4 LEDs flash once (in a sequential manner) and then the LEDs combination corresponding to the transmitter location return to light constantly as before.
5. Perform steps 3 - 5 for all other desired transmitters.
6. Exit from programming mode by pressing and holding for 6 seconds both the "CANCEL" button and the MODE button (automatic exit by time out will occur if no action is performed during 4 minutes).

# Deleting Wireless Transmitters from the System Memory

## Using PC:

By using a remote or local PC programmer, it is possible to delete enrolled wireless transmitters.

## Without PC:

Locally (without PC), wireless transmitters can be deleted from the Amber Link memory, as follows:

1. Press and hold both the "CANCEL" button and the right MODE button for 6 seconds. All 4 LEDs should flash to indicate that the system is in programming mode.
2. To select the desired transmitter to be deleted, click the right MODE button repeatedly until the desired transmitter location number is displayed (see Table 1). Each press advances to the next location (zone) number (1 - 15).
3. To delete a selected transmitter, press and hold the "CANCEL" button for 3 seconds. As a result, the LEDs combination of the respective deleted location (see Table 1) will flash indicating the location is now free.
4. To delete all the transmitters in the Amber Link memory, press and hold the "CANCEL" button for 6 sec until ALL LEDs light approx. 2 sec then only the LED of zone 1 blinks and the system is ready for enrolling.

## Wireless Devices Test

1. Press and hold both the "CANCEL" button and the right MODE button for 6 seconds. All 4 LEDs should flash to indicate that the system is in programming mode/Test mode.
2. Activate the transmitter you wish to test and listen to the system response. If the signal level received by the system is "Strong" or "Good", the system will respond with a success beep and RF red LED will light up during transmission. If the signal level is "Poor" the system will respond with 2 sec. long beep and the RF green LED blinks.  
During the TEST mode, the system will not dial to the Central Station.
3. Exit the test by pressing and holding both the "CANCEL" button and the right MODE button for 6 seconds (automatic exit by timeout will occur if no action is performed during 4 minutes).

## Reset to Factory Default

If you need to return to the preset factory default configuration, you can reset the panel to this configuration.

1. Press and hold both the "CANCEL" button and the right MODE button for 6 seconds. All 4 LEDs should flash to indicate that the system is in programming mode/Test mode.
2. Press the "CANCEL", "HELP", and "MODE" buttons simultaneously for an additional 8 seconds.

At this point, the panel is reset to the factory default configuration.

# MOUNTING THE UNIT

The Unit can be located on a table, or on a wall. In both cases the Unit should be near an electrical outlet and phone line.

## Mounting the Unit on a Table

Insert the AmberLink stand into the holes (see figure 8) and place the AmberLink on a table.

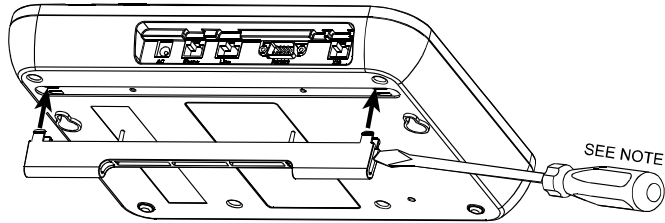
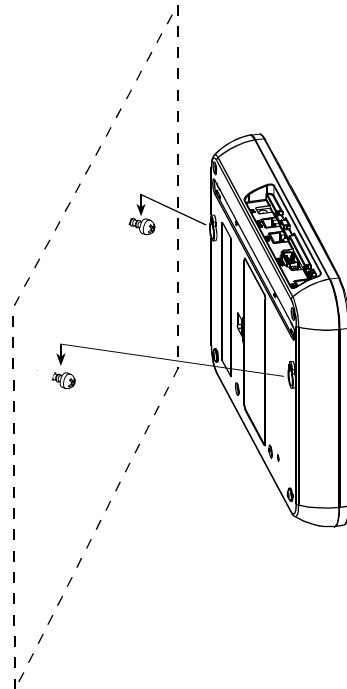

**Figure 8 – Table Stand Mounting**

**Note:** The table stand can be easily disassembled by inserting a screwdriver into the rib space of the stand and with the screwdriver pulling the stand away from the unit.

## Mounting the Unit on the Wall

1. Drill 2 holes in the mounting wall and insert wall anchors.
2. Insert 2 screws in the wall (leave a 5 mm or 0.2 inch gap between the screw heads and the wall).
3. Mount the AmberLink on the screws as shown in the illustration.



**Figure 9 - Wall Mounting**

## Using your AmberLink

Your AmberLink is the communication center of your system. When your pendant transmitter or optional fall-detector/smoke detector signals the AmberLink, the AmberLink contacts your Monitoring Center or private phones to report the emergency event.

Your AmberLink includes the following buttons.

- **HELP** – When pressed, an emergency alarm is reported to the Monitoring Center or to private phones.
- **CANCEL** – This button should be pressed to:
  - Stop dialing
  - Confirm a reminder
  - Reset the inactivity timer

## Using your Pendant Transmitter

The pendant transmitter can be used to initiate an emergency call and also to answer incoming calls.

- **Pendant Activation** - Your pendant transmitter lets you signal to the AmberLink from anywhere in your home when you need emergency assistance. You should wear your pendant transmitter whenever you are at home even in the shower or bath. Your pendant transmitter is waterproof.

Your pendant transmitter can be activated by simply pushing its red button. Once pushed, a signal is sent from the pendant transmitter to the AmberLink, the red LED on the pendant transmitter illuminates and a success beep is heard. The AmberLink then calls the Monitoring Center or a private phone.

If your phone is ringing, pressing the pendant's red button once will answer the incoming call. You can then talk over the unit's speakerphone. To end the speakerphone call and hang up, simply press the pendant button again.

- **Neckband** - You can wear the pendant transmitter using the neckband. Slip the tab on the neckband into the slot on the pendant transmitter and fasten the tab.
- **Optional Wristband** - Your pendant transmitter can also be used with an optional wristband. To make the pendant transmitter wristband smaller, slide the pendant transmitter towards the buckle. To make the wristband larger, slide the pendant transmitter away from the buckle.

## Calling for Emergency Assistance

If you need emergency assistance, press the button on your pendant transmitter or press the HELP button on your AmberLink. After you press the "HELP" button, you will hear a confirmation sound.

The AmberLink calls your Monitoring Center or a private phone and sends an emergency alarm. When your Monitoring Center representative or the person on the private phone answers, you can hear them talking to you through the AmberLink.

If you have a phone connected to the AmberLink and want to use the phone to talk with the representative, let the representative know and the Monitoring Center will return your call.

## Trouble

Trouble conditions are indicated when the Trouble LED lights steadily and beeps occur. The condition is immediately reported to the Monitoring Center.

Yellow LED	Definition
On	Low battery, AC failure, Line failure, Detector tamper, Inactivity
Blinks	GSM trouble (network failure, SIM card problem)

## Remote control by telephone

Both the central station and any person to whom the AmberLink unit is dialing can perform a number of actions using the AmberLink unit, as follows:

Pressed button	Performs
1	Half duplex: speaker ON, microphone OFF
3	Half duplex: microphone ON, speaker OFF
4	Increase speaker volume (up to 4 levels)
7	Decrease speaker volume (up to 4 levels)
5	High ambient microphone level
8	Low ambient microphone level
99	Disconnect the call

## MAINTAINING YOUR SYSTEM

The transmitter may get dirty as it's touched with your fingers. Clean it only with a soft cloth or sponge moistened lightly with a mixture of water and mild detergent, and wipe it dry immediately.

**The use of abrasives of any kind is strictly forbidden.**  
**Also, never use solvents such as kerosene, acetone or thinner.**

### Pendant transmitter Test

To test your pendant(s) regularly, your installer must enable this feature during configuration. At the scheduled time, the pendant's LED blinks to instruct the user to press the Transmit button to confirm the test.

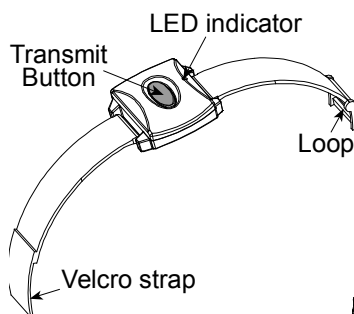

*Figure 10 – MCT-212 Pendant*

### When a Pendant's Battery is Low

When the MCT-212 pendant transmitter's battery is low, its LED flashes rapidly several times per second during transmission.

### When a Smoke Detector's Battery is Low

When a smoke detector's battery voltage is low, the smoke detector alerts you by beeping every 35 seconds until replacement of the detector's battery. The smoke detector's batteries should last from 5 to 8 years, depending on the battery type. To replace the batteries, refer to the instructions provided with the smoke detector.

## Unit Battery Replacement

Open battery compartment cover (see Figure 11). Insert one 8-battery pack and connect its connector to the AmberLink receptacle. Route the wire as shown in Figure 11.

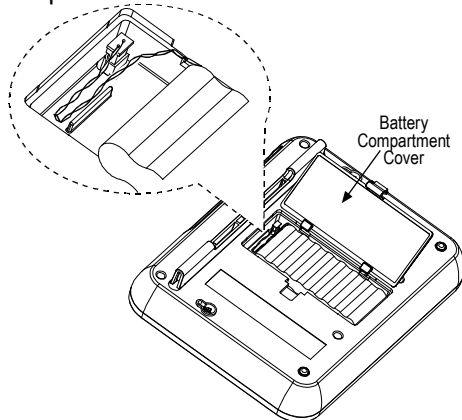

*Figure 11 – Replacing the Battery*

# APPENDIX A: HOME FIRE ESCAPE PLANNING

The onset of a fire can often spread rapidly throughout your home, leaving you with little time to escape safely. Getting out of the house depends, largely, on advance warning from smoke detectors together with an advance planning strategy – namely, a home fire escape plan familiar to all members of your family and which has previously been put into practice.

Perform the following steps:

- Make preparations with members of your family to conduct an evacuation plan.
- Draw a floor plan of your home, displaying two possible exit areas of each room, including windows. Don't forget to mark the location of every installed smoke detector.
- Test all smoke detectors periodically (this must be performed in a qualified testing laboratory), to ensure their serviceability. Replace batteries as required.
- Make sure that everyone understands the escape plan and is able to recognize the sound emitted from the smoke alarm. Verify that the escape routes are clear and that doors and windows can be opened easily.
- If windows or doors in your home have security bars, make sure that the bars have quick-release mechanisms on the inside, which, in the event of an emergency, can be opened immediately. Quick release mechanisms do not compromise your security, but increase the likelihood of safely escaping a home fire.
- Practice the escape plan at least twice a year. It is important that all members of the family participate, especially children and grandparents. Allow children to master the fire escape planning procedure before holding a fire drill at night while they are asleep. The objective here is to perform a fire drill, and not to frighten the children, so informing the children of the fire drill before they go to bed can be as effective as a surprise drill. If children or others do not awaken promptly to the sound of the smoke alarm, or if there are infants or family members with mobility disabilities, make sure that someone is assigned to assist them in the fire drill and in the event of a real-life emergency.
- Agree on an outside meeting place where everyone can meet once safely out of the house premises. Remember to get out of the house first, and then to call for help. Never go back inside the house until authorized by the fire department.
- Ensure that all members of the family memorize the emergency phone number of the fire department. This will allow a member of the household to call for help from a cellular phone or from a neighbor's home.
- Be fully prepared for a real fire: when a smoke alarm sounds, get out of the house immediately and do not return to the house until authorized to do so by the fire department!
- If you live in an apartment building, make sure that you are familiar with the building evacuation plan. In the event of a fire, use the stairs, never the elevator.

Inform guests or visitors to your home about your family's fire escape plan. When visiting other homes, ask the occupants about their escape plan, if they have one. If they do not, point out the importance of such a plan and offer to help them prepare one. This is particularly important when children attend "sleepovers" at friends' homes.

## Warning

Owners Instructions Notice: Smoke detectors shall not be removed by anyone except by occupants.

## APPENDIX B: CONTACT ID EVENT CODES

EVENT CODE	EVENT DESCRIPTION
000	COMMUNICATION LOSS
101	EMERGENCY
105	MISSED REMINDER
110	FIRE
121	DURESS
137	TAMPER - CONTROL PANEL
151	GAS ALARM
152	EXTREME FREEZING CONDITIONS
153	FREEZING (0° C/32°F)
154	FLOOD ALARM
158	HOT TEMPERATURE
159	COLD TEMPERATURE
301	RESTORE AC POWER
302	LOW BATTERY – CONTROL PANEL
308	SYSTEM SHUTDOWN
311	BATTERY DISCONNECTED
344	RF RECEIVER JAMMING
350	COMMUNICATION RESTORE
351	TELEPHONE LINE TROUBLE
373	FIRE DETECTOR TROUBLE
380	GAS TROUBLE
380	PROBE TROUBLE
381	LOSS OF SUPERVISION
383	TAMPER - SENSOR
384	LOW BATTERY – TRANSMITTER
393	FIRE DETECTOR NEEDS CLEANING
401	SYSTEM ARMED – AWAY
441	SYSTEM ARMED – HOME
459	RECENT CLOSE EVENT
602	PERIODIC TEST REPORT
612	PENDANT TEST UNSUCCESSFUL
641	SENIOR WATCH TROUBLE
654	SYSTEM INACTIVE

# APPENDIX C: SIA EVENT CODES

EVENT CODE	ZONE #	EVENT DESCRIPTION
QA	35	EMERGENCY ALARM (CONSOLE)
RP	35	PERIODIC TEST
NA	35	INACTIVITY ALARM
AT	35	A/C LOSS
AR	35	A/C LOSS RESTORE
YT	35	LOW BATTERY TO CONSOLE
YR	35	RESTORAL TO LOW BATTERY TO CONSOLE
YM	35	SYSTEM BATTERY MISSING
YS	35	SYSTEM SHUTDOWN (POWER OFF THE UNIT)
RR	35	POWER UP (POWER ON THE UNIT)
MI	35	MISSED REMINDER
L_	90	LISTEN IN (OPEN TWO WAY VOICE SESSION)
AB	35	ALARM CANCELLED (RESET BUTTON ON CONSOLE PUSHED)
XX		PENDANT TEST FAILURE
XT		LOW BATTERY TO TRANSMITTER
XR		RESTORAL TO LOW BATTERY TO TRANSMITTER
XS		TRANSMITTER LOST SUPERVISION
XJ		RESTORAL TO TRANSMITTER LOST SUPERVISION
TA		TAMPER ALARM
TR		TAMPER RESTORE
MA		MEDICAL ALARM (NECK PENDANT AND WATCH)
MT		MEDICAL TRANSMITTER LOW BATTERY
MR		RESTORAL TO MEDICAL TRANSMITTER LOW BATTERY
GA		GAS ALARM
GT		GAS SENSOR LOW BATTERY
GR		RESTORAL TO GAS SENSOR LOW BATTERY
GS		GAS SENSOR LOST SUPERVISION
GJ		RESTORAL TO GAS SENSOR LOST SUPERVISION
FA		FIRE ALARM
FH		FIRE ALARM RESTORE
FT		FIRE SENSOR LOW BATTERY
FR		RESTORAL TO FIRE SENSOR LOW BATTERY
FS		FIRE SENSOR LOST SUPERVISION
FJ		RESTORAL TO FIRE SENSOR LOST SUPERVISION
WA		FLOOD ALARM
WT		FLOOD ALARM SENSOR LOW BATTERY
WT		FLOOD ALARM SENSOR LOW BATTERY
WR		RESTORAL TO FLOOD ALARM SENSOR LOW BATTERY
WS		FLOOD ALARM SENSOR LOST SUPERVISION
WJ		RESTORAL TO FLOOD ALARM SENSOR LOST SUPERVISION

# APPENDIX D: COMPLIANCE and STATEMENTS

## Compliance

§ 15.19(a)(3)

### AmberLink

This device complies with Part 15 of the FCC Rules.

Operation is subject to the following two conditions:

- (1) This device may not cause harmful interference, and
- (2) this device must accept any interference received,

§ 15.21

## Statement

Changes or modifications to this equipment not expressly approved by the party responsible for compliance could void the user's authority to operate the equipment.

5. For a Class B digital device the instructions furnished the user shall include the following or similar statement, placed in a prominent location in the text of the user or instruction manual:

§ 15.105

## Statement

**NOTE:** This equipment has been tested and found to comply with the limits for a Class B digital device, pursuant to part 15 of the FCC Rules. These limits are designed to provide reasonable protection against harmful interference in a residential installation. This equipment generates, uses and can radiate radio frequency energy and, if not installed and used in accordance with the instructions, may cause harmful interference to radio communications. However, there is no guarantee that interference will not occur in a particular installation. If this equipment does cause harmful interference to radio or television reception, which can be determined by turning the equipment off and on, the user is encouraged to try to correct the interference by one or more of the following measures:

-Reorient or relocate the receiving antenna.

-Increase the separation between the equipment and receiver.

-Connect the equipment into an outlet on a circuit different from that to which the receiver is connected.

-Consult the dealer or an experienced radio/TV technician for help.

Due to FCC requirements in the U.S.A. and IC in Canada, transmission power is limited. This limited power output should provide a maximum operating range of 400 feet in "open space".

This range may be reduced further when operating within buildings, or around other obstructions to R.F. signals. Other operating frequencies as approved for use in other parts of the world have a higher allowed transmission power which can result in greater range.

This equipment should be installed in accordance with Chapter 2 of the National Fire Alarm Code, ANSI/NFPA 72.

# APPENDIX E: CUSTOMER PREMISES EQUIPMENT AND WIRING

The REN is used to determine the number of devices that may be connected to a telephone line. Excessive RENs on a telephone line may result in the devices not ringing in response to an incoming call. In most but not all areas, the sum of RENs should not exceed five. To be certain of the number of devices that may be connected to a line, as determined by the total RENs, contact the local telephone company. The REN of an alarm system is part of the product identifier that has the format US: **VSOAL01BANBERGSLA**.

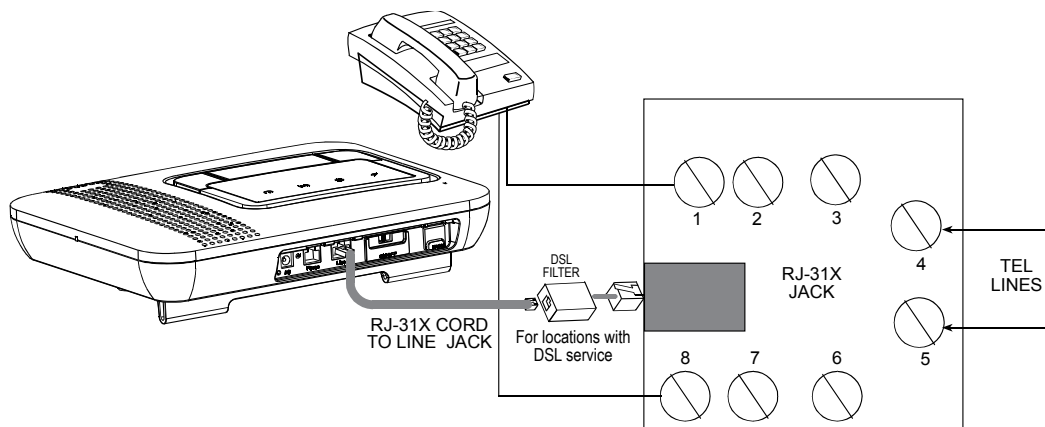

**Note:** For whole house line seizure with DSL service present on the phone line, you must install a filter. It is suggested to use the DSL alarm filter model Z-A431PJ31X manufactured by Excelsus Technologies, or equivalent. This filter simply plugs into the RJ-31X jack and allows alarm reporting without breaking the internet connection.

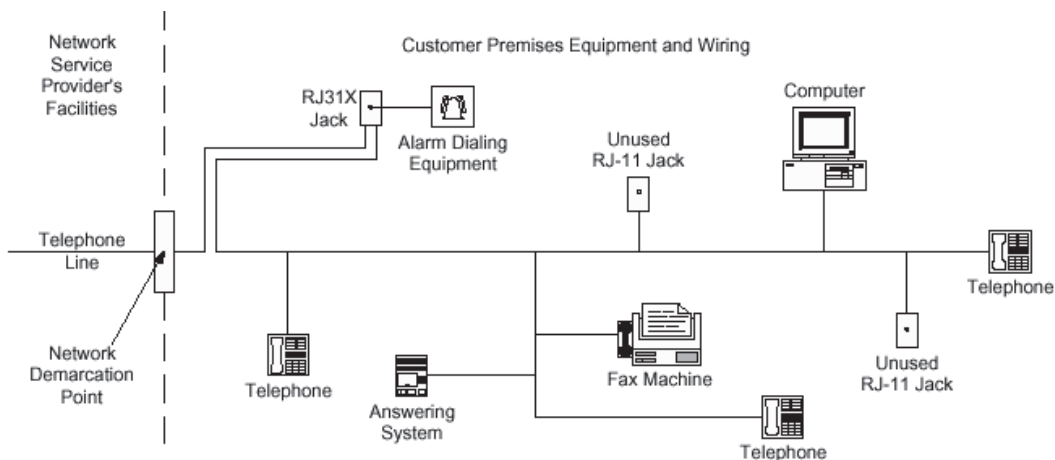

## Customer Information

The required customer information is provided in the User Guide (manual).

1. This equipment, wireless emergency response system, model “AmberLink”, complies with Part 68 of the FCC Rules and the requirements adopted by the ACTA. On the bottom panel of this equipment is a label, that contains among other information, a product identifier in the format US:VSOAL00BAMBERNA. If requested, this number must be provided to the telephone company.
2. This equipment is designed to be connected to the telephone network using RJ11 connector which complies with Part 68 rules and requirements adopted by ACTA and properly installed RJ31X connector. See Installation Instructions for details.
3. If the “AmberLink” causes harm to the telephone network, the telephone company will notify you in advance that temporary discontinuance of service may be required. If advance notice is not practical, you will be notified as soon as possible. Also, you will be advised of your right to file a complaint with the FCC if it is necessary.
4. The telephone company may make changes in its facilities, equipment, operations or procedures that could affect the operation of the equipment. If this happens, the telephone company will provide advance notice in order for you to make necessary modifications to maintain uninterrupted service.
5. If the equipment is causing harm to the telephone network, the telephone company may request to disconnect the equipment until the problem is resolved.
6. The “AmberLink” installation is described in the User Guide. Connection to telephone company provided coin service is prohibited. Connection to party lines service is subject to state tariffs.
7. Wireless emergency response system must be able to seize the telephone line and place a call in an emergency situation. It must be able to do this even if other equipment (telephone, answering system, computer modem, etc.) already has the telephone line in use. To do so, “AmberLink” must be connected to a properly installed RJ31X jack that is electrically in series with and ahead of all other equipment attached to the same telephone line. Proper installation is depicted in Appendix E. If you have any questions concerning these instructions, you should consult your telephone company or a qualified installer about installing the RJ31X jack and “AmberLink” for you.





**W.E.E.E. Product Recycling Declaration**

For information regarding the recycling of this product you must contact the company from which you originally purchased it. If you are discarding this product and not returning it for repair then you must ensure that it is discarded as specified by your supplier. This product is not to be thrown away with everyday waste.

Directive 2002/96/EC Waste Electrical and Electronic Equipment.

**Visonic®**

**VISONIC LTD. (ISRAEL):** P.O.B 22020 TEL-AVIV 61220 ISRAEL. PHONE: (972-3) 645-6789, FAX: (972-3) 645-6788

**VISONIC INC. (U.S.A.):** 65 WEST DUDLEY TOWN ROAD, BLOOMFIELD CT. 06002-1376. PHONE: (860) 243-0833, (800) 223-0020. FAX: (860) 242-8094

**VISONIC LTD. (UK):** 7 COPPERHOUSE COURT, CALDECOTTE, MILTON KEYNES. MK7 8NL. TEL.: +44(0)845 0755800

FAX: +44(0)845 0755801 PRODUCT SUPPORT: +44(0)845 755802

**VISONIC GmbH (D-A-CH):** KIRCHFELDSTR. 118, D-40215 DÜSSELDORF, TEL.: +49 (0)211 600696-0, FAX: +49 (0)211 600696-19

**VISONIC IBERICA:** ISLA DE PALMA, 32 NAVE 7, POLIGONO INDUSTRIAL NORTE, 28700 SAN SEBASTIÁN DE LOS REYES, (MADRID), ESPAÑA. TEL (34)

91659-3120, FAX (34) 91663-8468. [www.visonic-iberica.es](http://www.visonic-iberica.es)

INTERNET: [www.visonic.com](http://www.visonic.com)

©VISONIC LTD. 2011 D-303166 AmberLink™ USER GUIDE Rev 1, 11/11

