

GLASSTECH

Glass Break Detector

Visonic®

Installation Instructions

1. INTRODUCTION

The GlassTech is a revolutionary, microprocessor-controlled glass-break detector using original sound image recognition methods that differ from those used by other glass break detectors. Sophisticated techniques are applied in the GlassTech for reliable distinction between the sound pattern created when breaking glass framed in an outer wall, and the sound patterns created when breaking unframed glass, bottles, plates, etc.

The GlassTech's remarkable qualities were achieved by systematic analysis of the acoustic effects in the frequency, time and amplitude domains. Diverse room reverberations were also studied, to discover how local acoustics affected the recognition of true as well as false alarms.

The digital signal processing carried out by the GlassTech relates to several time phases, from the initial impact on the glass window to the final sound of falling fragments. Sounds undergo statistical analysis based on 18 different sound signatures. A

sound that does not qualify as a true alarm is not automatically identified as a false alarm unless positively recognized as such.

The GlassTech has an alarm memory that can be enabled or disabled with a jumper. If the alarm memory is enabled, the red alarm LED illuminates and latches upon alarm (see para. 3.7).

An important feature of the GlassTech is that upon power up, it automatically runs self-test diagnostic routines (see para. 4.3A), and checks the local ambient conditions. The diagnostic self-test is repeated periodically, to verify trouble-free operation of the electronic circuitry. Models with the -AM suffix also run an anti-masking routine (see Para. 4.3B) at 30 minute intervals, to verify that the microphone is neither masked nor damaged.

The GlassTech can take part in perimeter zone protection, without worrying about occasional shattering of glassware, bottles and food plates or other sounds produced by common appliances and utensils.

2. SPECIFICATIONS

Supply Voltage: 9 - 16 VDC

Current Consumption: 20 mA approx. (standby), 25 mA approx. (on alarm).

Maximum Detection Range: 10 m (30 ft) radius at 170° if glass size is 30 x 60 cm (1 x 2 ft) to 3 x 3 m (10 x 10 ft); 7m (21 ft) radius at 170° if glass size is 30 x 30 cm (1 x 1 ft) to 30 x 60 cm (1 x 2 ft).

Glass Types: Plate, tempered, wired & laminated.

Glass Size: 0.3 x 0.3 m (1 x 1 ft) to 3 x 3 m (10 x 10 ft).

Glass Thickness: *Plate:* 2.4 to 6.4 mm (3/32 to 1/4"); *tempered:* 3.2 to 6.4 mm (1/8 to 1/4 in.); *laminated:* 3.2 to 6.4 mm (1/8 to 1/4 in.); *wired:* 6.4 mm (1/4 in.).

Room Size: Not larger than 15 x 15 m (45 x 45 ft); not smaller than 3 x 3 m (10 x 10 ft).

Min. Distance from Protected Glass: 1.2 m (4 ft).

Sensor Type: Electret Microphone.

Relay Output: Normally closed (fail-safe) contacts with 18Ω resistor in series. Rating - 0.1A resistive / 30 VDC.

Alarm Duration: Relay contacts open for about 3 sec.

Alarm Indications: GREEN LED flickers in response to audio sounds; lights steadily while in TEST mode.

RED LED - lights for 3 seconds on alarm, and latches ON if the LATCH jumper is set to ON.

Power-Up Self Test Indication: Green and red LEDs flash alternately.

Trouble Indication: Green and red LEDs light steadily.

Trouble (TRB) Output: Open collector type, 100 mA max.

Test Period Timeout: 5 minutes.

Tamper Switch: Normally closed. Rating - 50 mA resistive / 30 VDC. Do not wire in series with the alarm relay contacts.

RFI Immunity: >30 V/m up to 1 GHz (not verified by UL).

Mounting: Surface and flush mounting on walls and ceilings.

Compatible Single-Gang Boxes: Carlon models B108B, B118A, B120A, A58381D for new construction prewires; B114R for existing construction.

Optional Mounting Accessories:

BR-1: swivel bracket, adjustable 30° down and 45° left, 45° right.

BR-3: same as BR-1, with ceiling adapter.

Operating Temp.: -10°C to 50°C (14°F to 122°F).

Storage Temp.: -20°C to 60°C (-4°F to 140°F).

Dimensions (H x W x D): 68 x 51 x 23 mm (2-11/16 x 2 x 7/8 in.).

Weight: 50 gr (1-3/4 oz).

Color: White.

Patents: U.S. Patents 5,515,029 and 5,608,377.

MODELS AVAILABLE

GLASSTECH (UL-Listed): Surface-mounted model.

GLASSTECH -F: Flush-mounted model.

GLASSTECH-AM (UL-Listed): Surface mounted model with anti- masking.

GLASSTECH-AM/F: Flush mounted with anti-masking model.

Compliance with Standards: EN 50131-1 Grade 2, Class II

3. INSTALLATION

3.1. Mounting - General Guidelines

The GlassTech is suitable for inclusion in perimeter loops that protect occupied and unoccupied sites.

The protected pane should measure at least 30 x 30 cm (1 x 1 ft). Optimum results will be obtained with glass panes sized 30 x 60 cm (1 x 2 ft) to 3 x 3 m (10 x 10 ft). Glass types and thickness are given in Section 2.

The detection range of the GlassTech is exemplified in Figure 1, where two windows are protected by a single detector. Since room acoustics influence the effective detection range, typical rather than maximum ranges are shown.

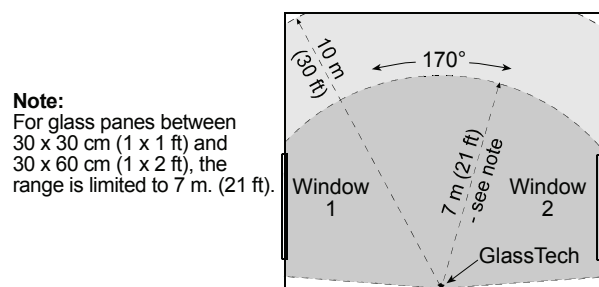

Figure 1. Coverage Pattern

You will obtain best detection and maximum false alarm protection by observing the following rules:

- A. Select the location carefully:** Mount the GLASSTECH in the same room with the protected glass pane, preferably on a wall facing the glass, or on an adjoining wall or on the ceiling.
- B. Do not mount the detector on the same wall as the protected glass pane.**
- C. Observe room size limits:** Avoid installation in rooms larger than 15 x 15 meters (45 x 45 ft) and sites where the ceiling is higher than 4.5 m (15 ft).
IMPORTANT: Adding detectors in a room larger than specified will not overcome this limitation.
- D. Do not install too close to the glass:** Mount the detector at least 1.2 m (4 ft) away from the protected glass, or from any wall with glass.
- E. Do not install in rooms smaller than 3 x 3 m (10 x 10 ft):** It would be impractical to install in display windows or display cases (that have two or more flexible walls - glass, plywood, plexiglass).
- F. Keep away from noise sources:** Electrical power cables, air-conditioners, air compressors, blowing air ducts, and loud noise sources such as powerful speakers, doors etc.
- G. Avoid installation in room corners:** Room corners are not an ideal mounting location, especially if the protected glass is smaller than 30 x 60 cm (1 x 2 ft).
- H. Do not install at all in very noisy areas:** Avoid small kitchens and rooms with noisy machinery or production. Multiple sound sources create a difficult environment for glass break detectors.
- I. Select a stable mounting surface:** Brick and concrete walls are ideal, drywall is also suitable.
- J. Ensure an obstacle-free sound path:** A direct line between detector and protected glass is very important - detection around corners cannot be guaranteed. Internal wooden shutters in the sound path may prevent detection.
- K. Never ignore sound muffling, lined or insulated drapes:** All these could adversely affect the detector's performance.
- L. Beware of damp places:** The unit is not sealed and may fail to function due to excess moisture.
- M. Use a swivel bracket if required:** Two optional brackets are available (see Paragraph 3.6).

Additional points to consider:

- A.** GlassTech is designed to detect shattering of glass framed in an outside wall. Breaking unframed glass (bottles, plates etc.) within the room will be identified as a false alarm.
- B.** GlassTech is not designed to detect the breaking of any type of hinged glass doors. Do not use it for this purpose.
- C.** Despite the GlassTech's high degree of sophistication, in rare cases and under specific conditions, certain noise bursts can duplicate the sound image of window glass breakage.
- D.** The GlassTech is not intended to detect events such as glass cracking by applying slow pressure or glass breaking by drilling or firing bullets at the glass. Glass break detectors should be backed up by interior detectors.
- E.** The GlassTech is not guaranteed to detect window breakage if any type of plastic film is adhered to the inside surface of the glass.
- F.** The GlassTech is not guaranteed to detect double-glass window breakage.
- G.** Before running any wiring, we recommend to mount the detector temporarily at the chosen location, power it up from a 9 or 12 volt battery and test the effective detection range with a glass break sound simulator (as instructed in Para. 4.2). The test can be repeated several times in several locations until the optimum mounting point is determined.

3.2 Disassembling the Detector (Fig. 2)

To disassemble the detector proceed as follows:

- A.** Pry loose one side of the trim strip, with a fingernail or a small screwdriver. If the trim strip doesn't come loose easily, try the other side. Remove the trim strip and save it for later use.
- B.** Remove the screw that fastens the front cover to the base and take the cover off.

- C.** Insert a screwdriver blade into the slot at the right side of the PCB (see Figure 5) and dislodge the printed circuit board from the right-side retaining tab. Remove the printed circuit board and put it aside carefully.

Note: for surface mounting, refer to Para. 3.3 below. For flush mounting, refer to Para. 3.4 below. Then finish as directed in 3.5 below.

3.3 Surface Mounting (GlassTech & GlassTech-AM)

The unit can be mounted directly on a flat surface or on an optional swivel bracket (see Paragraph 3.6). Use **countersunk head screws** (supplied) through the two holes in the base to attach the base firmly to the wall or to the ceiling. Be sure to pass the wires into the base through the wiring inlet. If the wires are routed down from the ceiling, use the vertical wiring channel at the rear of the base. Then carry on as directed in paragraph 3.5.

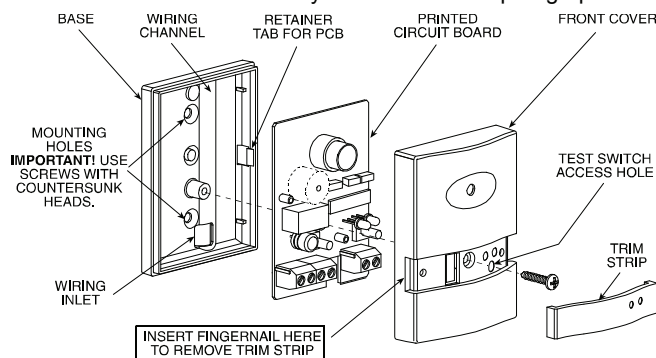

Figure 2. GlassTech - Exploded View

3.4. Flush Mounting (GlassTech-F & GlassTech-AM/F)

An adapter box, a decorative frame and 4 screws are included in the GTFK kit for installation in plastic single-gang electrical switch boxes (see Figure 3 and Section 2 for details). Having disassembled the detector, proceed as follows:

- A.** Attach the detector's base to the adapter box, using two short, **countersunk head screws** (not shown in Figure 3) through the holes in the base into the two plastic standoffs in the adapter box.

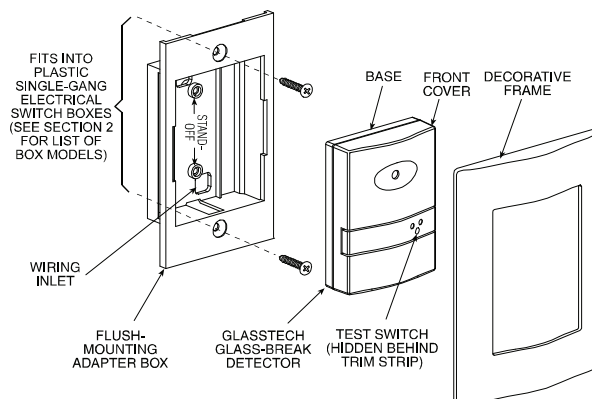

Figure 3. GlassTech -F and -AM/F, Installation with GTFK

- B.** Fit the adapter box, with the detector base mounted inside, into the single-gang box already recessed into the wall. Be sure to pass the wires into the base through the wiring inlet.
- C.** Fasten the adapter to the single-gang box with the two conical head screws through the top and bottom extensions. Then carry on as directed in Para. 3.5.

3.5 Mounting - Final Procedure

- A.** Push the detector's printed circuit board into the base, until it snaps into place, held firmly by the retainer tabs at both sides.
- B.** Set the jumpers as required for the particular installation (see Para. 3.7).
- C.** Complete the wiring as described in Para. 3.8.
- D.** Remount the front cover. Fasten it with the screw and push the trim strip back into place. In flush mountings, fit the decorative frame over the entire assembly and push it in until it clicks into place.

Caution! with -AM and -AM/F models, the front cover must be put in place within 60 seconds after power up. Otherwise, the unit will adapt itself to the "no cover" condition and a trouble alert will result when the cover is put back (see Section 4.3B).

3.6. Optional Mounting Brackets (Fig. 4)

Two optional mounting brackets are available:

BR-1 Surface Mounted: Swivel, surface-mounted bracket for greater flexibility when facing the protected window. The BR-1 is adjustable 30° downward and 45° left, 45° right.

BR-3 – Ceiling Mounted: Swivel bracket kit for easy installation on ceilings. Consists of the BR-1 and a ceiling mounting adapter.

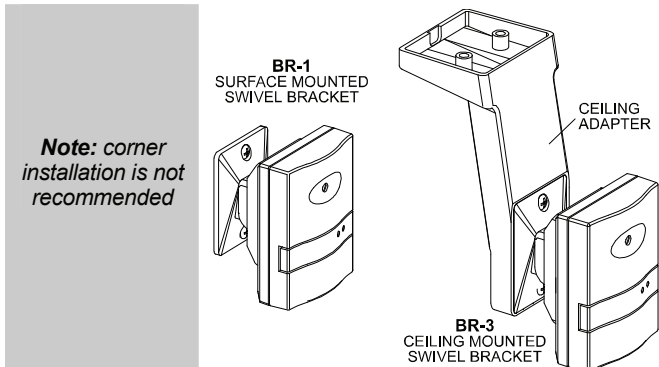

Figure 4. Optional Swivel Mounting Brackets

3.7 Setting the Jumper Links (Fig. 5)

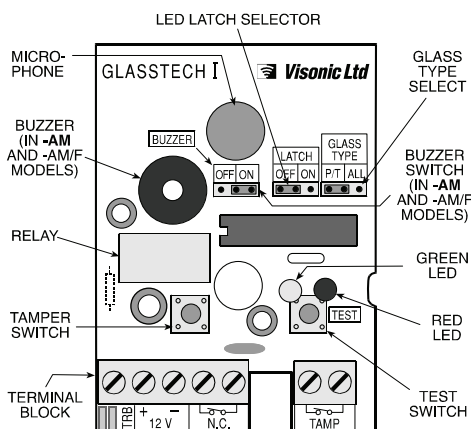

Figure 5. Printed Circuit Board Layout

A. The LED Latch Selector

Set the jumper to ON if you wish the red indicator LED to remain illuminated after an alarm (memory indication). The memory indication may be reset by temporarily removing the LED latch jumper from its ON position or temporarily disconnecting the supply voltage (a 1-second power down period is sufficient).

4. TESTING

4.1. Initial Testing

A. During initialization, the detector samples the ambient noise. Therefore, at power up, eliminate any strong irregular noise such as loud radio, air-conditioner hum, loud knocking etc.

B. Power up the detector. The two LEDs will flash rapidly and, if all is normal, they will both turn off within 60 seconds. **With -AM models, the front cover must be remounted before this time expires: a trouble condition will result from belated remounting of the cover.**

If a malfunction or abnormal audio environment exists after the first 60 seconds, both LEDs will light steadily until the trouble is cleared. Simultaneously, the TRB output will pull to ground and will remain grounded until the trouble is cleared.

Setting the jumper to OFF disables the alarm memory. With the memory disabled, the red indicator will light for about 3 seconds upon alarm and will then extinguish.

B. The Glass Type Selector

The GlassTech is optimized for reliable glass break detection, whatever the type of the glass pane – **plate, laminated, wired and tempered**. Nevertheless, certain additional criteria have extra benefits for the protection of **plate and tempered** glass. These can included in the decision making process for a more accurate, positive discrimination between true and false alarms.

For this reason, if the protected glass is of the **plate or tempered** type, set the jumper to the P/T position (factory preset). If you aren't sure of the type of glass, consult the glass supplier. If you fail to identify the type of glass, or once you identify the glass as laminated or wired, set the jumper to ALL.

C. Buzzer Selector (GlassTech-AM and GlassTech-AM/F)

The anti-masking function (see Section 4.3) requires that the buzzer be enabled. The buzzer selector may be set to OFF to disable the buzzer if for some reason you wish to cancel this function. If the jumper is set to ON, the buzzer will sound constantly when a malfunction (trouble) occurs and for 3 seconds only upon alarm.

3.8 Wiring

To route wires into the detector, use the rectangular opening at the bottom of the base, and the channel on the back of the base. The channel allows wire routing from the ceiling along the back of the detector and into the base. Proceed as follows (see Figure 6):

A. Connect the **TAMP**. N.C. terminals to a normally closed 24-hour zone of the alarm control panel. The tamper contacts open when the cover is removed.

B. Connect the **N.C.** relay terminals to a normally closed burglar protection zone or perimeter zone of the control panel. The relay contacts will open for 3 seconds upon alarm, or permanently during power loss.

C. Connect the **12V (+)** and **(-)** terminals to a 9 to 16 VDC source. Reverse polarity protection is provided. If you intend to use the alarm memory, make sure there is a provision for temporary disconnection of power. The power supply requires battery backup of 4 hours minimum (for UL-listed installations) or in accordance with local regulations.

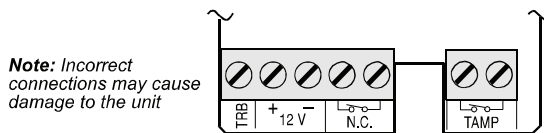

Figure 6. GLASSTECH Terminal Block

D. Connect the **TRB** and **12V(-)** terminals across the E.O.L. resistor of a 24-hour zone or a burglar zone, to cause a trouble alert in case of detector trouble. **For UL installations, the trouble output must be connected to the trouble circuit of a UL-listed burglary control unit.**

Note: the detector and the control panel must have a common ground (-) connection.

As long as steady lighting is maintained, the detector is not ready for operation. In -AM and -AM/F models, the buzzer will sound an alert, if the BUZZER jumper is set to ON.

Note: In addition, a diagnostic self-test routine is run at regular intervals during normal operation (see Section 4.3).

C. Test the detector's stability by thumping the protected glass or a flexible partition (if available in the room). The green LED should respond by lighting briefly, but should go off immediately and remain extinguished. The red alarm LED shouldn't light during this test.

If the green LED continues to light or flickers sporadically with apparently no background noise, try to change the mounting location.

- D. Set the glass type jumper to the P/T position and test the detector's immunity to false alarms by creating 'household' sounds: let a telephone ring, or clap your hands, or play a loud audio recording or even break a dish or a drinking glass. The green LED will flicker in response to any of these sounds, indicating that the detector is functional. However, no alarm should result - the red alarm LED must remain off.

Note: If the detector responds by alarming, replace it with another unit and retest.

4.2 Glass Break Simulation Test

If tested in its regular operating mode, the detector won't respond reliably to commercial glass break simulators. The GLASSTECH generally identifies the sound generated by these simulators as a false alarm. A special TEST switch has therefore been included, to permit temporary downgrading of the GLASSTECH's signal processing and decision making algorithms. This allows the unit to be tested with simulators such as model FG-700 or FG-701.

Even in the test mode, a special combination of audio frequencies must be generated for triggering the detector without actually breaking glass. To achieve the correct effect, thump the protected glass pane with a cushioned object, hard enough to trigger the simulator. The displacement of the glass by the impact provides the low frequency signal, and the simulator responds by sounding the required high frequency signal.

Note: The FG-701 manual instructs you to switch certain glass break detectors into the test mode by sounding a special signal. This is not applicable to the GlassTech which has a test switch.

To assure success of the simulator-aided test, use a glass pane of at least 0.5 x 0.5 m (1.5 x 1.5 ft). It is recommended (but not obligatory) to set the glass type jumper to the ALL position.

- A. Remove the trim strip from the detector's front cover, to access the test switch (located just below the two LEDs).
- B. Insert a pointed object (such as a pen) into the test switch access hole and press for one second. This will switch the GlassTech to the test mode for a 5-minute period. The Green LED will light steadily throughout the test period.
- C. Switch the simulator to the TEST and FLEX modes.
- D. Hold the simulator close to the protected glass and press the simulator's start button.
- E. Within 8 seconds from pressing the start button, thump the glass with a cushioned object hard enough to produce a low frequency wave - take care not to shatter the glass.

- F. The simulator should respond by sounding its own high-frequency signal, and the detector should alarm. The alarm can be verified by watching the red LED illuminate. In -AM and -AM/F models, the buzzer should sound, provided that it is enabled with the buzzer jumper.

- G. Remount the trim strip at the front. Normal operation resumes automatically 5 minutes after having pressed the test switch.

Note: if the LED latch jumper is set to ON, the LED will light constantly upon termination of the test. To extinguish the LED, temporarily remove the latch jumper from the ON position or momentarily disconnect the power supply to the detector.

Important! conduct a simulation test at least once every 6 months.

4.3 Self-Diagnostic Routines

A. Regular Self Tests

All GlassTech models run a self-diagnostic routine once every 30 minutes, and if a malfunction is discovered, a TROUBLE period begins - **both LEDs light steadily, the trouble output pulls to ground and the buzzer (in -AM models) sounds an alert.** The trouble indications will stop upon removal of the cause for trouble.

Note: The alarm relay is not affected by the trouble condition.

B. Anti-Masking (GlassTech -AM and GlassTech -AM/F)

The anti-masking function protects against attempts at reducing or totally suppressing the GlassTech's detection ability.

GlassTech models with the -AM suffix are equipped with an on-board buzzer and a buzzer ON/OFF jumper. For anti-masking purposes, the buzzer emits a short quiet chirp once every 30 minutes. Any lasting deviation from the normal signal pickup level will initiate a 1 minute period of extensive testing. If the audio disturbance still exists after the extensive testing period, a trouble indication, similar to the one obtained in regular self tests, will result (see Para. A above). The buzzer sounds an alert for as long as the masking condition exists.

Important! The anti masking capability can be checked only when the power-up 1-minute test period is over. The detector will start to indicate trouble within about 15 minutes after having been masked. Removal of the masking will cause the trouble indication to cease within a few seconds.

WARRANTY

Visonic Limited (the "Manufacturer") warrants this product only (the "Product") to the original purchaser only (the "Purchaser") against defective workmanship and materials under normal use of the Product for a period of twelve (12) months from the date of shipment by the Manufacturer.

This Warranty is absolutely conditional upon the Product having been properly installed, maintained and operated under conditions of normal use in accordance with the Manufacturers recommended installation and operation instructions. Products which have become defective for any other reason, according to the Manufacturers discretion, such as improper installation, failure to follow recommended installation and operational instructions, neglect, willful damage, misuse or vandalism, accidental damage, alteration or tampering, or repair by anyone other than the manufacturer, are not covered by this Warranty.

The Manufacturer does not represent that this Product may not be compromised and/or circumvented or that the Product will prevent any death and/or personal injury and/or damage to property resulting from burglary, robbery, fire or otherwise, or that the Product will in all cases provide adequate warning or protection. The Product, properly installed and maintained, only reduces the risk of such events without warning and it is not a guarantee or insurance that such events will not occur.

THIS WARRANTY IS EXCLUSIVE AND EXPRESSLY IN LIEU OF ALL OTHER WARRANTIES, OBLIGATIONS OR LIABILITIES, WHETHER WRITTEN, ORAL, EXPRESS OR IMPLIED, INCLUDING ANY WARRANTY OF MERCHANTABILITY OR FITNESS FOR A PARTICULAR PURPOSE, OR OTHERWISE. IN NO CASE SHALL THE MANUFACTURER BE LIABLE TO ANYONE FOR ANY CONSEQUENTIAL OR INCIDENTAL DAMAGES FOR BREACH OF THIS WARRANTY OR ANY OTHER WARRANTIES WHATSOEVER, AS AFORESAID.

THE MANUFACTURER SHALL IN NO EVENT BE LIABLE FOR ANY SPECIAL, INDIRECT, INCIDENTAL, CONSEQUENTIAL OR PUNITIVE DAMAGES OR FOR LOSS, DAMAGE, OR EXPENSE, INCLUDING LOSS OF USE, PROFITS, REVENUE, OR GOODWILL, DIRECTLY OR INDIRECTLY ARISING FROM PURCHASER'S USE OR INABILITY TO USE THE PRODUCT, OR FOR LOSS OR DESTRUCTION OF OTHER PROPERTY OR FROM ANY OTHER CAUSE, EVEN IF MANUFACTURER HAS BEEN ADVISED OF THE POSSIBILITY OF SUCH DAMAGE.

THE MANUFACTURER SHALL HAVE NO LIABILITY FOR ANY DEATH, PERSONAL AND/OR BODILY INJURY AND/OR DAMAGE TO PROPERTY OR OTHER LOSS WHETHER DIRECT, INDIRECT, INCIDENTAL, CONSEQUENTIAL OR OTHERWISE, BASED ON A CLAIM THAT THE PRODUCT FAILED TO FUNCTION.

However, if the Manufacturer is held liable, whether directly or indirectly, for any loss or damage arising under this limited warranty, **THE MANUFACTURER'S MAXIMUM LIABILITY (IF ANY) SHALL NOT IN ANY CASE EXCEED THE PURCHASE PRICE OF THE PRODUCT**, which shall be fixed as liquidated damages and not as a penalty, and shall be the complete and exclusive remedy against the Manufacturer.

When accepting the delivery of the Product, the Purchaser agrees to the said conditions of sale and warranty and he recognizes having been informed of.

Some jurisdictions do not allow the exclusion or limitation of incidental or consequential damages, so these limitations may not apply under certain circumstances.

The Manufacturer shall be under no liability whatsoever arising out of the corruption and/or malfunctioning of any telecommunication or electronic equipment or any programs.

The Manufacturers obligations under this Warranty are limited solely to repair and/or replace at the Manufacturer's discretion any Product or part thereof that may prove defective. Any repair and/or replacement shall not extend the original Warranty period. The Manufacturer shall not be responsible for dismantling and/or reinstallation costs. To exercise this Warranty the Product must be returned to the Manufacturer freight pre-paid and insured. All freight and insurance costs are the responsibility of the Purchaser and are not included in this Warranty.

This warranty shall not be modified, varied or extended, and the Manufacturer does not authorize any person to act on its behalf in the modification, variation or extension of this warranty. This warranty shall apply to the Product only. All products, accessories or attachments of others used in conjunction with the Product, including batteries, shall be covered solely by their own warranty, if any. The Manufacturer shall not be liable for any damage or loss whatsoever, whether directly, indirectly, incidentally, consequentially or otherwise, caused by the malfunction of the Product due to products, accessories, or attachments of others, including batteries, used in conjunction with the Products. This Warranty is exclusive to the original Purchaser and is not assignable. This Warranty is in addition to and does not affect your legal rights. Any provision in this warranty which is contrary to the Law in the state or country where the Product is supplied shall not apply.

Warning: The user must follow the Manufacturer's installation and operational instructions including testing the Product and its whole system at least once a week and to take all necessary precautions for his/her safety and the protection of his/her property.

1/08



W.E.E. Product Recycling Declaration

For information regarding the recycling of this product you must contact the company from which you originally purchased it. If you are discarding this product and not returning it for repair then you must ensure that it is returned as identified by your supplier. This product is not to be thrown away with everyday waste.
Directive 2002/96/EC Waste Electrical and Electronic Equipment.



VISONIC LTD. (ISRAEL): P.O.B 22020 TEL-AVIV 61220 ISRAEL. PHONE: (972-3) 645-6789, FAX: (972-3) 645-6788

VISONIC INC. (U.S.A.): 65 WEST DUDLEY TOWN ROAD, BLOOMFIELD CT. 06002-1376. PHONE: (860) 243-0833, (800) 223-0020. FAX: (860) 242-8094

VISONIC LTD. (UK): 7 COPPERHOUSE COURT, CALDECOTTE, MILTON KEYNES. MK7 8NL. PHONE: (0870) 7300800 FAX: (0870) 7300801

INTERNET: www.visonic.com

©VISONIC LTD. 2008 GLASSTECH DE1896- (REV. 9, 03/08)



MADE IN ISRAEL