

# VMX-150D / 300D / 450D

## 2-Beam Infrared Detectors



## Installation Instructions

### 1. FEATURES

- State-of-the-art circuit
- Durable housing
- Dual photoelectric beam sensor
- Minimum false alarms
- Indoor and outdoor use
- Excellent immunity to freezing, snow, rain, fog, and other bad weather conditions
- Anti-frost design
- N.C. tamper switch included

**Note:** The VMX-150D / 300D / 450D are designed to detect movement of an intruder. However, note that environmental disturbances in the protected area may also cause the sensor to create an alarm. Test the detector periodically for continuous satisfactory operation before arming the alarm system.

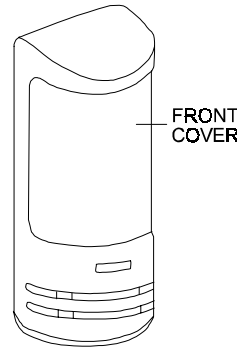

Figure 1. General View

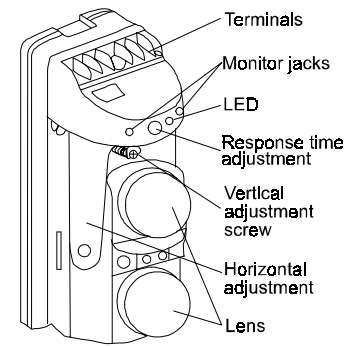

Figure 2. Inside View

### 2. SPECIFICATIONS

**Outdoor Usable Distance:** 25 / 50 / 75 m (82 / 164 / 246 ft)

**Indoor Usable Distance:** 50 / 100 / 150 m (164 / 328 / 492 ft)

**Beam:** Infrared photoelectric, 1 kHz, 940 nm infrared pulse

**Interrupt Time:** Adjustable from 50 ms to 500 ms.

**Power Input:** 10 to 24 VDC

**Current (mA):** 55 (VMX-150D) / 60 (VMX-300D) / 65 (VMX-450D)

**Alarm Output:** N.C., 30 VDC, 1 A max., 1 s

**Transmitter LED:** Green (indicates transmit)

**Receiver LEDs:** Red (indicates alarm) and green (indicates standby)

**Align Angle:** ± 5° vertical. ± 90° horizontal

**Temperature:** -25 to 60°C (-13 to 140°F)

**Mounting:** Wall or pole (pole clamps and screws included)

**Size:** 67 X 167 X 66.5 mm (2.64 X 6.57 X 2.62 in.)

**Wire Connection:** Screw-type terminals

**Case:** PC, ABS plastic, waterproof

**Tamper:** N.C., becomes N.O. when cover is removed

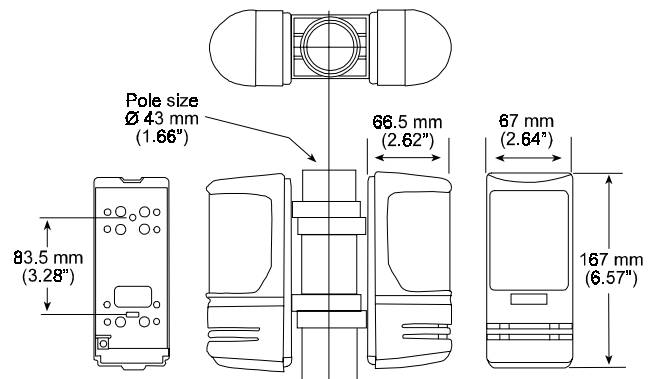
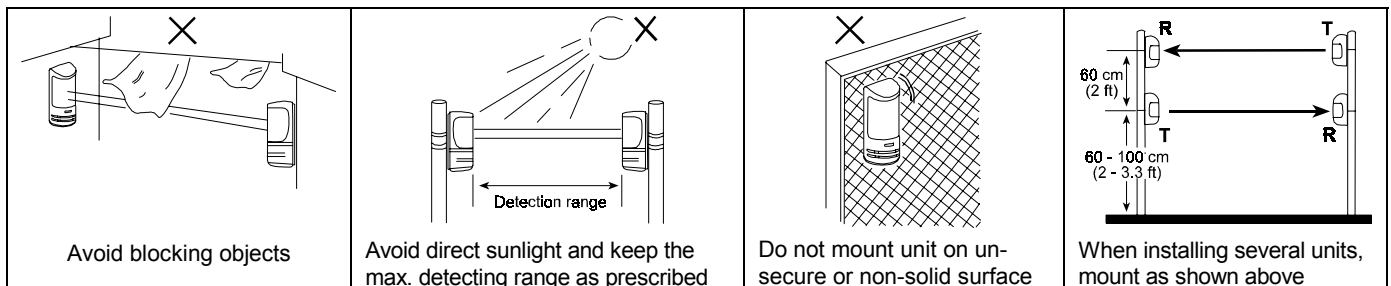

Figure 3. Dimensions

### 3. INSTALLATION



#### 3.1 Mounting

##### A. Wall Installation

- (1) Loosen the cover locking screw and remove the cover. Loosen the unit setting screw at the lower part of the unit. Slide the mounting plate downwards and remove it.
- (2) Feed the wires through the wiring holes of the mounting plate before fixing the plate to the wall.
- (3) Fix the mounting plate firmly on the wall with the mounting screws supplied.

##### B. Pole Installation

- (1) Use a 43 mm (1.66") mounting pole
- (2) Fix the clamps onto mounting plate with supplied screws. Place the clamps around the pole and tighten firmly with the pole locking screws.

- (3) Feed the wires through the wiring hole of the mounting plate.

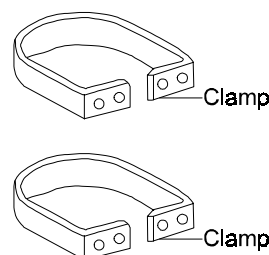

Figure 4. Pole Clamps

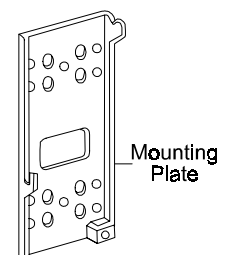

Figure 5. Mounting Plate

### 3.2 Wiring (transmitter and receiver)

- (+): Connect to the (+) output of a 10 to 24 VDC power source.
- (-): Connect to the (-) output of a 10 to 24 VDC power source.
- **TAMPER:** Connect to the N.C. tamper circuit of the control panel.
- **ALARM (receiver only):** Connect to N.C. burglar zone input.

**NOTE:** Grounding may be necessary, depending on the location.

### 3.3 Alignment

#### A. Eyeball - make horizontal / vertical alignments visually:

- Look into one of the transmitter's viewfinders (one of the four holes located between the two lenses) at a 45° angle.
- Adjust the lens horizontally by turning it left and right by hand until the receiver is clearly seen in the viewfinder.
- Use a screwdriver to turn the vertical adjustment screw (above the lens on the lens bracket) clockwise or counterclockwise until the receiver is clearly seen in the viewfinder.
- Repeat the same steps for the receiver.

**Note:** If you cannot see the opposite unit in the viewfinder, put a sheet of white paper near the unit to be seen. Move your eyes about 5 cm away from the viewfinder and try again.

#### B. Meter - fine tune the receiver's adjustment:

- Set the range of a volt-ohm meter (VOM) to 0-9 VDC.
- Insert the red (+) probe into the (+) terminal and the black (-) probe into the (-) terminal. Measure the voltage.
- Adjust the horizontal angle by hand until the VOM indicates the highest voltage.
- Adjust the vertical angle by turning the vertical adjustment screw until the VOM indicates the highest voltage.
- Do not interrupt the beam while adjusting. 2.7 VDC is the maximum possible reading. Anything over 2.0 VDC is good, and over 1.5 VDC is acceptable. The higher the reading, the better. In misty areas, the reading must be over 2.0 VDC.

### 3.4 Testing the system

- Power up the transmitter and receiver. If the LED remains steadily ON even when the beam is not interrupted, realign the units.
- Walk between the transmitter and receiver at various speeds to interrupt the beams. Adjust the delay time control as needed.
- Detection will occur only if both the upper and lower beams are simultaneously interrupted.

- The beam interrupt control determines how long the beam can be interrupted before triggering the alarm.
- Adjust the beam interrupt control as required at the specific site. You may need to make adjustments later after completing the walk test.
- The following figures show the typical values for sensing an adult.

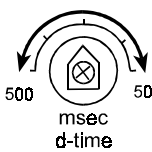

Fast running (50 ms)



Jogging (100 ms)



Fast walk (200 ms)



Normal walk (350 ms)



Slow motion (500 ms)

## 4. TROUBLESHOOTING

TROUBLE	CHECK	REMEDY
Transmitter LED does not light	Incorrectly wired and/or insufficient voltage	Ensure the power supply to the transmitter is 10 to 24 VDC
Receiver LED never lights up when the beam is interrupted	Insufficient voltage Beam reflected away from receiver Beams not simultaneously interrupted	Raise voltage Clean the cover Check overall installation
Beams interrupted and LED lights, but no alarm is triggered	Alarm trigger cable may be cut, or relay contacts stuck due to overloading	Check wiring and the effect of the load on the output level or overhaul the unit
Alarm LED continuously illuminated	Lenses out of alignment Beams are blocked Cover is foggy or dirty	Realign the lenses Remove any obstacles Clean the cover
Alarm trigger becomes erratic in bad weather	Lenses out of alignment	Check overall system installation. If still erratic, realign the lenses
Frequent false alarms triggered by leaves, birds, etc	Too sensitive Bad location	Reduce beam interrupt speed Change location

### WARRANTY

Visonic Ltd. and/or its subsidiaries and its affiliates ("the Manufacturer") warrants its products hereinafter referred to as "the Product" or "Products" to be in conformance with its own plans and specifications and to be free of defects in materials and workmanship under normal use and service for a period of twelve months from the date of shipment by the Manufacturer. The Manufacturer's obligations shall be limited within the warranty period, at its option, to repair or replace the product or any part thereof. The Manufacturer shall not be responsible for dismantling and/or reinstallation charges. To exercise the warranty the product must be returned to the Manufacturer freight prepaid and insured.

**This warranty does not apply in the following cases:** improper installation, misuse, failure to follow installation and operating instructions, alteration, abuse, accident or tampering, and repair by anyone other than the Manufacturer.

This warranty is exclusive and expressly in lieu of all other warranties, obligations or liabilities, whether written, oral, express or implied, including any warranty of merchantability or fitness for a particular purpose, or otherwise. In no case shall the Manufacturer be liable to anyone for any consequential or incidental damages for breach of this warranty or any other warranties whatsoever, as aforesaid.

This warranty shall not be modified, varied or extended, and the Manufacturer does not authorize any person to act on its behalf in the modification, variation or extension of this warranty. This warranty shall apply to the Product only. All products, accessories or attachments of others used in conjunction with the Product, including batteries, shall be covered solely by their own warranty, if any. The Manufacturer shall not be liable for any damage or loss whatsoever, whether directly, indirectly, incidentally, consequentially or otherwise, caused by the malfunction of the Product due to products, accessories, or attachments of others, including batteries, used in conjunction with the Products.

The Manufacturer does not represent that its Product may not be compromised and/or circumvented, or that the Product will prevent any death, personal and/or bodily injury and/or damage to property resulting from burglary, robbery, fire or otherwise, or that the Product will in all cases provide adequate warning or protection. User understands that a properly installed and maintained alarm may only reduce the risk of events such as burglary, robbery, and fire without warning, but it is not insurance or a guarantee that such will not occur or that there will be no death, personal damage and/or damage to property as a result.

**The Manufacturer shall have no liability for any death, personal and/or bodily injury and/or damage to property or other loss whether direct, indirect, incidental, consequential or otherwise, based on a claim that the Product failed to function.** However, if the Manufacturer is held liable, whether directly or indirectly, for any loss or damage arising under this limited warranty or otherwise, regardless of cause or origin, the Manufacturer's maximum liability shall not in any case exceed the purchase price of the Product, which shall be fixed as liquidated damages and not as a penalty, and shall be the complete and exclusive remedy against the Manufacturer.

**Warning:** The user should follow the installation and operation instructions and among other things test the Product and the whole system at least once a week. For various reasons, including, but not limited to, changes in environmental conditions, electric or electronic disruptions and tampering, the Product may not perform as expected. The user is advised to take all necessary precautions for his /her safety and the protection of his/her property.

6/91



VISONIC LTD (ISRAEL): P.O.B 22020 TEL-AVIV 61220 ISRAEL. PHONE: (972-3) 645-6789, FAX: (972-3) 645-6788

VISONIC INC. (U.S.A.): 10 NORTHWOOD DRIVE, BLOOMFIELD CT. 06002-1911. PHONE: (860) 243-0833, (800) 223-0020 FAX: (860) 242-8094

VISONIC LTD. (UK): UNIT 1, STRATTON PARK, DUNTON LANE, BIGGLESWADE, BEDS. SG18 8QS. PHONE: (01767) 600857 FAX: (01767) 601098

INTERNET: WWW.VISONIC.COM

©VISONIC LTD. 2000 VMX-150D / 300D / 450D DE9980- (REV. 0, 4/00)



Made in Korea  
for Visonic Ltd.